



## Advantix Bath drain

- system dimension 100

### Scope of supply

top 100x100 mm rotatable and height-adjustable, plastic frame, grate stainless steel 1.4301, plug, sealing flange, removable odour trap, inlet DN40, drain pipe with ball joint

**drainage capacity according to DIN EN 1253**

**Model 4935.1**

**Article 557 119**

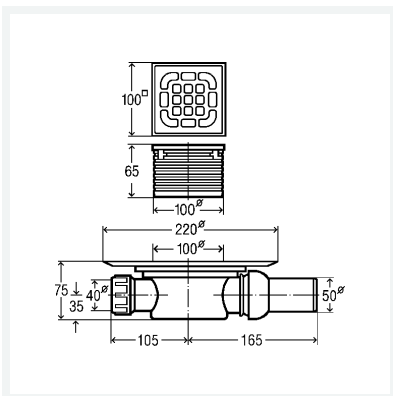

## Properties

Water seal height	WSH	30 mm
Load class	LC	K=300 kg
Drainage capacity 10 mm (in accordance with EN 1253)	DC 10	0.4 l/s
Drainage capacity 20 mm (in accordance with EN 1253)	DC 20	0.6 l/s
Nominal diameter	DN	50
Horizontal drain	HD	✓
Weight	550 g	
Volume	5472.3 cm <sup>3</sup>	
Material	plastic	