

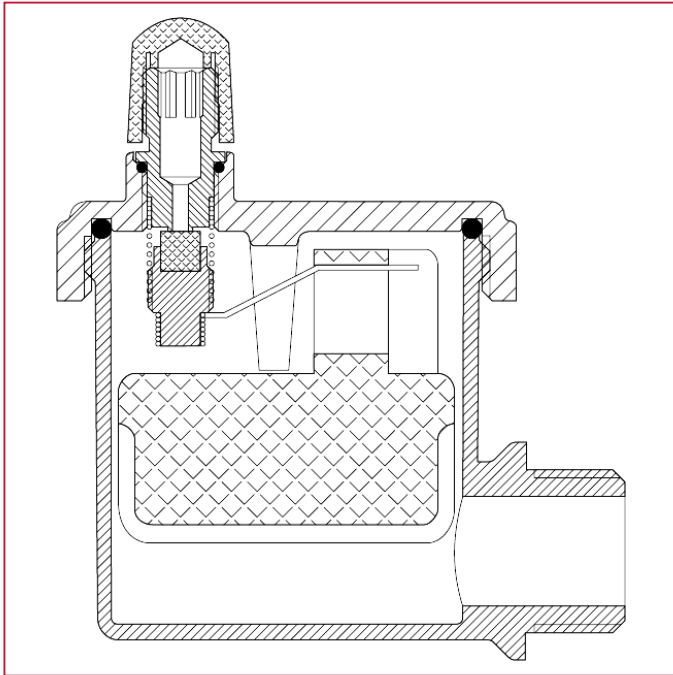

## AIR VENT VALVES AND SAFETY VALVES

### 364 Automatic air-vent valve, side inlet

#### MATERIALS



POS.	DESCRIPTION	N.	MATERIAL
1	Body	-	Brass UNI EN 1982-2000
2	Cap	-	Brass CW617N
3	Float	-	Polyethylene
4	Cap	-	Polyethylene
5	Washer	-	NBR
6	Mechanism	-	Brass
7	Junction	-	Acetal resin
8	Lever	-	Acetal resin
9	Stop	-	Acetal resin



## AIR VENT VALVES AND SAFETY VALVES

### 364 Automatic air-vent valve, side inlet

#### OVERALL DIMENSIONS

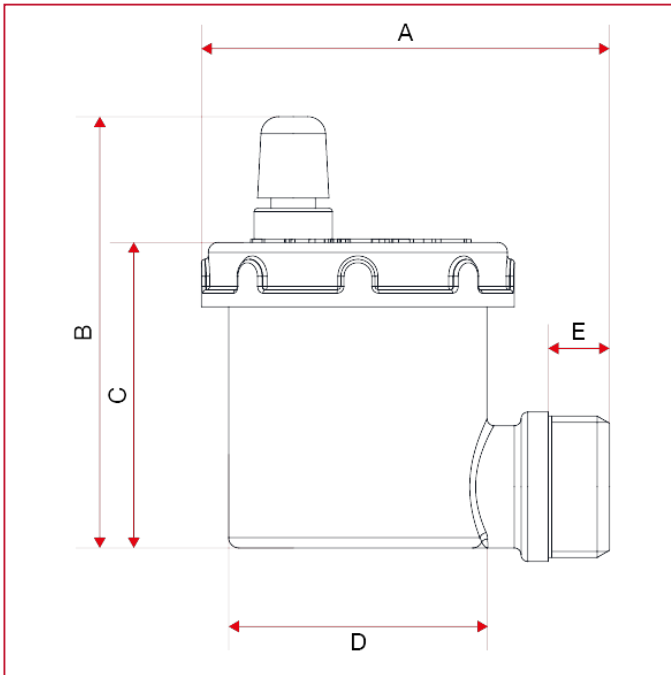

	3/8"	1/2"
A	60	60
B	63,5	63,5
C	45	45
D	38	38
E	9	9
Kg/cm <sup>2</sup> bar	10	10
LBS - psi	145	145



## AIR VENT VALVES AND SAFETY VALVES

### 364 Automatic air-vent valve, side inlet

#### OPERATION AND INSTALLATION:

The automatic air vent valves are installed in order to remove the air that accumulates in heating and air conditioning systems. Thanks to their functioning, without need of manual operation, they allow to avoid for certain and permanently harmful phenomena that could compromise the life and the performance of any systems. Especially, it is possible to limit the negative effect of galvanic corrosion (due to extreme presence of oxygen inside the piping) and cavitation. Moreover, these valves allow to optimize the heating and cooling power of each system, since they avoid the formation of air pockets inside radiators and fan-coil units.

Such valves have to be installed in vertical position only, on top of each systems and, generally, where it is the evidence of air pockets' formation (distribution manifolds, riser pipes, etc.)

Under normal operating conditions, it is recommended to leave the cap loose.

The air flow of these valves raises in accordance to the working pressure of a system, up to reach a maximum figure when the pressure raises up to 6 bar.

Here below there is the flow rate chart of these valves, when the system is being filled: as it is possible to read, the chart includes a maximum working pressure of 6 bar, since this figure is higher than an usual working pressure in heating and air-conditioning system (generally they work till 3 bar).

