

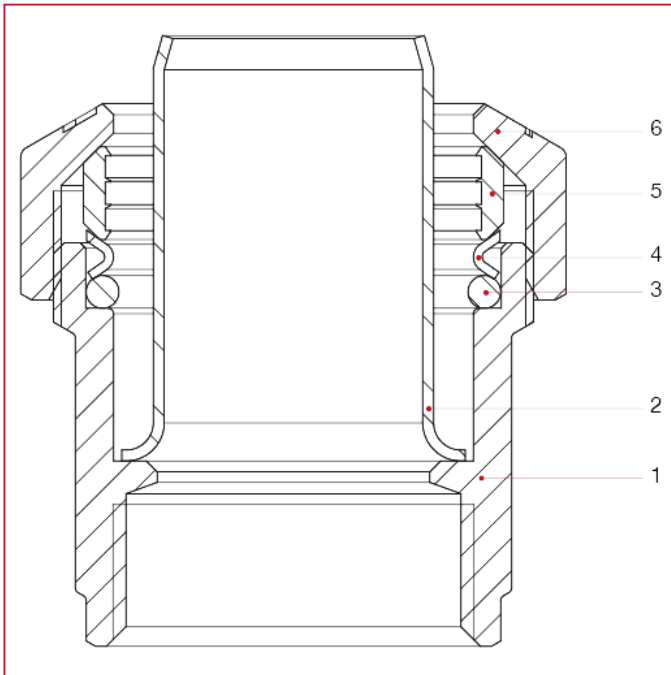

# VX ANSCHLÜSSE FÜR POLYETHYLEN

## 010 Gerader Anschluss, Innengewinde

### WERKSTOFFE



NUM.	BESCHREIBUNG	Qt	MATERIALIEN
1	Gehäuse	1	Messing CW617N
2	Stützhülse	1	Edelstahl AISI 304
3	O-Ring	1	NBR
4	Unterlegscheibe O-Ring	1	Edelstahl AISI 304
5	Klemmring	1	Vernickeltes Messing CW617N
6	Ring	1	Messing CW617N



# VX ANSCHLÜSSE FÜR POLYETHYLEN

## 010 Gerader Anschluss, Innengewinde

### GESAMTABMESSUNGEN

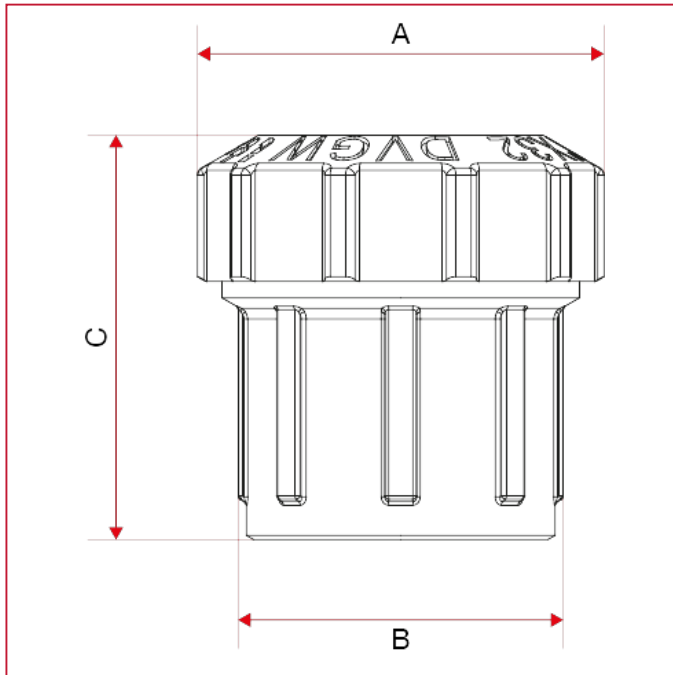

	1/2"x20	3/4"x25	1"x32	1"1/4x40	1"1/2x50	2"x63
DN	15	20	25	32	40	50
A	34	40	50	61	71	89
B	27	33	40	50	60	75
C	39,5	44,8	49,8	57,4	65,4	81,3



# VX ANSCHLÜSSE FÜR POLYETHYLEN

## 010 Gerader Anschluss, Innengewinde

### ANLEITUNG INSTALLATION



### KOMBINATION DER ANSCHLÜSSE VX 4"X110 mm

